



Smart NXi



Payload up to
600 Kg ■

Maximum horizontal reach
3.037 mm ■

Repeatability
0,2 mm ■

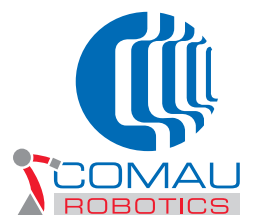

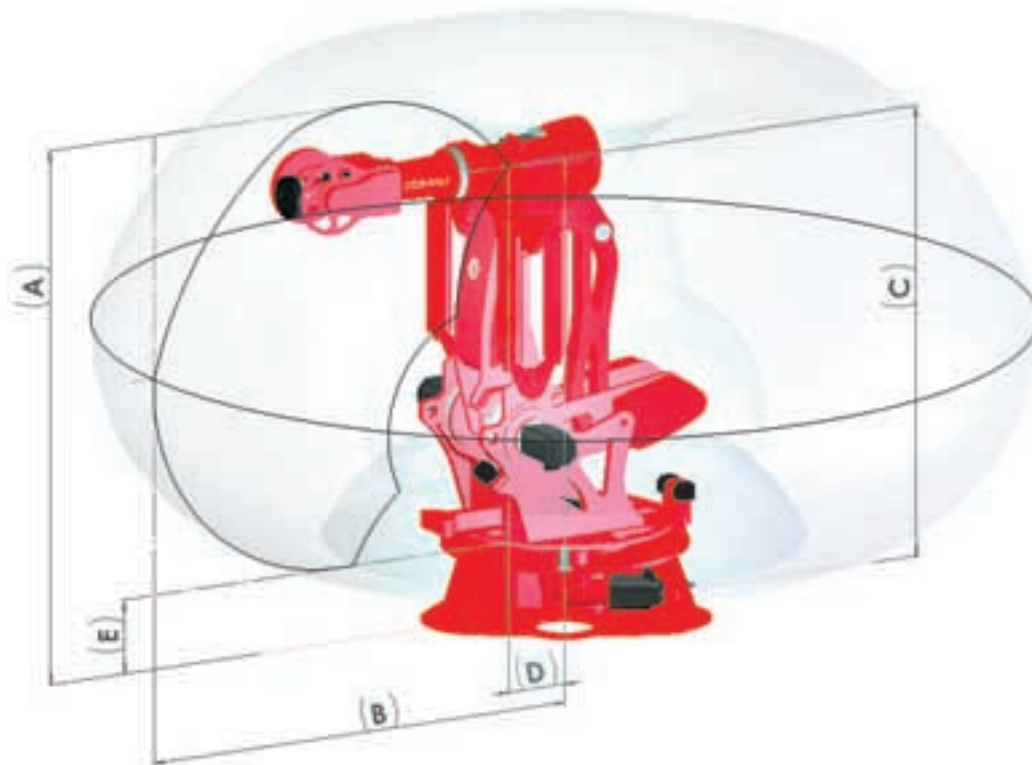

- Assembly
- Foundry
- Handling Packaging
- Polishing Deburring
- Processing Machining
- Wood-Glass Machining

ROBOT APPLICATIONS

Model	NX1 600-3.0				
Number of axes	6				
Load at wrist (Kg)	600				
Additional load on forearm (Kg)	60				
Torque of axes (Nm)	4	3.021			
	5	3.021			
	6	1.471			
Axes stroke (Speed)	1	+/- 180° (80°/s)			
	2	+65°-55° (80°/s)			
	3	-63°-202° (80°/s)			
	4	+/- 280° (56°/s)			
	5	+/- 120° (56°/s)			
	6	+/- 2.700° (113°/s)			
Repeatability ISO 9283 (mm)	0,2				
Maximum horizontal reach (mm)	3.037				
Installation position	Floor				
Protection Class	IP65/IP67 wrist				
Operating Areas (mm)	A	3.547			
	B	3.036			
	C	2.992			
	D	412			
	E	489			
Foundry version	Available				

Sales * +39 011 0045406 * sales.robotics@comau.com
 Service * +39 011 0045553 * service.robotics@comau.com
www.comau.com/robotics

